

PC Based Weigh Labeller

Model : TSMI700

PC based mid-speed weigh labeller featuring USB memory back up, stainless steel open frame design conveyor and on board help screens and videos for ease of use.

FEATURES

- NMI approved for trade use
- user friendly, full colour TFT touch screen display
- printing by 80 mm wide, 300 DPI thermal head providing high print resolution and true type window print fonts
- stand alone 304 stainless steel open frame design conveyor, enhanced ease of cleaning and hygiene, IP65 rated
- quick release conveyors & belts, removed easily without tools
- under/over setpoint linked to label print on in-range products (selectable for each PLU)
- on board help screens & videos include programming, label roll changes, maintenance and fault finding
- Windows XP embedded, 20 Gb hard drive, 256 MB Ram, Intel Celeron processor
- USB memory back up

OPTIONS

- single or twin sweep arm rejecter station
- 108 mm, 300 DPI thermal head
- V deck conveyors for round shaped products
- TSHI700.NET back office data maintenance
- controlling software via Ethernet network



Refer page 2 for specifications

Specifications may change without notice

LABELLING EQUIPMENT

PC Based Weigh Labeller

Model : TSMI700

SPECIFICATIONS

Package Size	Length: 80 - 300 mm Width: 40 - 250 mm
Label Size	Minimum: 30 mm wide x 28 mm high Maximum: 120 mm wide x 150 mm high
Label Roll	300 mm outside diameter, 76 mm core, inside or outside wound
Label Application	by 10 finger touch applicator
Print Method	direct thermal, 300 DPI (12 dots/mm)
Operating Speed	80 packs/min for 110 mm high label \leq 3 kg capacity 60 packs/min for 110 mm high label $>$ 3 kg capacity Speed is dependent on label length and printed information
HDD Capacity	20 GB
Power Requirements	240V AC 50 Hz single phase
Air Requirements	Minimum 4 bar at 50 to 300 litres/min external clean, dry air
IP Protection	Console: to IP65 standard Labeller: to IP43 standard Conveyor: to IP65 standard
Operating Temp.	0 to +40 degrees celsius
Operating Humidity	15 to 85% RH

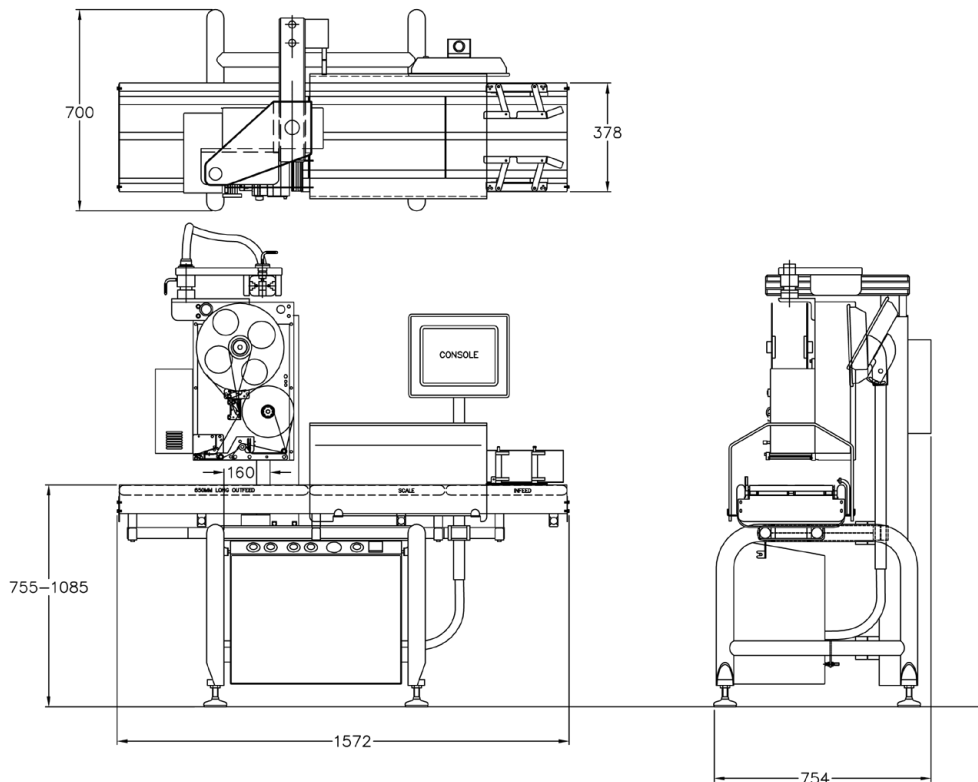

Specifications may change without notice

LABELLING EQUIPMENT

LABELS | LABELLING EQUIPMENT | PACKAGING EQUIPMENT
ESL & DIGITAL SIGNAGE | WEIGHING SCALES | POS SYSTEMS
FOOD EQUIPMENT | MAINTENANCE & REPAIRS | HIRE

1300 970 111
enquiries@wedderburn.com.au
www.wedderburn.com.au