



PC Based High Speed In-Line Weigh Labeller

Model : TSHI701

Increase your throughput with the HI701 high speed in line weigh labeller. With PC touch screen operation and modular design it will grow with your business.

FEATURES

- NMI approved for trade use
- user friendly, full colour TFT touch screen display
- printing by 108 mm wide, 300 DPI thermal head providing high print resolution and true type window print fonts
- modular 304 stainless steel open frame design conveyor, enhanced ease of cleaning and hygiene, IP65 rated
- quick release conveyors & belts, removed easily without tools
- under/over setpoint linked to label print on in-range products (selectable for each PLU)
- on board help screens & videos include programming, label roll changes, maintenance and fault finding
- Windows XP embedded, 20Gb hard drive, 256 M Ram, Intel Celeron processor
- USB memory back up

OPTIONS

- additional top or bottom labellers for promotion or supplementary labels to show ingredients or similar information. Up to 5 labellers in combination max
- interchangeable V deck conveyors for round shaped products
- long scale conveyor versions for items up to 475 mm in length
- WS Stick "n" Sleeve labeller for single label application to top, side and bottom of trays
- power drop flap conveyor, single or twin sweep arm rejectors
- 80 mm, 300 DPI thermal head
- TSHI700.NET back office data maintenance controlling software via Ethernet network



Refer page 2 for specifications

Specifications may change without notice

LABELLING EQUIPMENT

LABELS | LABELLING EQUIPMENT | PACKAGING EQUIPMENT
ESL & DIGITAL SIGNAGE | WEIGHING SCALES | POS SYSTEMS
FOOD EQUIPMENT | MAINTENANCE & REPAIRS | HIRE

1300 970 111
enquiries@wedderburn.com.au
www.wedderburn.com.au

PC Based High Speed In-Line Weigh Labeller

Model : TSHI701

SPECIFICATIONS

Weighing Capacities	3 kg x 1 g 6 kg x 2 g
Package Size	Length: 80 - 300 mm Width: 40 - 250 mm Height: 180 mm Maximum
Label Size	Minimum: 30 mm wide x 28 mm high Maximum: 120 mm wide x 150 mm high
Label Roll	300 mm outside diameter, 76 mm core, inside or outside wound
Label Application	by 10 finger touch applicator
Print Method	direct thermal, 300 DPI or 12 dots/mm
Operating Speed	90 packs/min for 100mm high label speed is dependent on label length and printer information
HDD Capacity	20 GB
Power Requirements	240V AC 50 Hz single phase
Air Requirements	Minimum 4 bar at 50 to 300 litres/min external clean, dry air
IP Protection	Console: to IP65 standard Labeller: to IP43 standard Conveyor: to IP65 standard
Operating Temp.	0 to +40 degrees celsius
Operating Humidity	15 to 85% RH

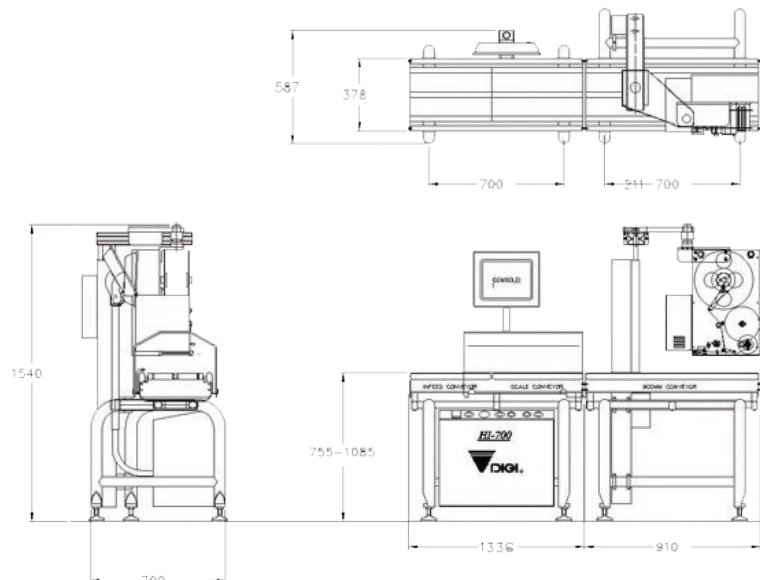

Specifications may change without notice

LABELLING EQUIPMENT

LABELS | LABELLING EQUIPMENT | PACKAGING EQUIPMENT
ESL & DIGITAL SIGNAGE | WEIGHING SCALES | POS SYSTEMS
FOOD EQUIPMENT | MAINTENANCE & REPAIRS | HIRE

1300 970 111
enquiries@wedderburn.com.au
www.wedderburn.com.au