



Weigh-Wrap-Price Labeller with Automatic Infeed

FULLY INTEGRATED WEIGH-WRAP-LABELLING SYSTEM
WITH ENHANCED AUTOMATION OPTIONS

Model: AW5600AT2AI Series



AW5600AT2AI Fully Integrated Weigh Wrap Price Labeller with Automatic Infeed and enhanced automation options.

Enhanced automation options elevate the AW5600AT2AI into a class of its own.

In addition to weighing, wrapping, calculating pack price and labelling all in one efficient pass, the new automatic infeed feature improves packing efficiency and sets the foundation for further automation vital in high-speed high-volume food packaging. It's legal for trade use in Australia and an ideal system for busy supermarkets, central packaging sites and factories.

Like all AW5600 Weigh Wrap Labellers, the AW5600AT2AI uses dynamic film stretching technology to reduce film consumption and costs, and deliver clean tidy wrapping and labelling that looks stunning on the store shelf and increases consumer appeal.

15" Large Full Colour Touch Screen

The user-friendly operator screen improves efficiency and flexible formatting means size, colour and location can be changed to suit your operation.

- Preset and frequently used function keys can be assigned for quick access
- Large memory supports the ever-increasing need for print items
- Label content can be previewed on the display prior to printing to prevent labelling errors
- The screen angle is adjustable to ensure good viewing for all operators and lighting conditions
- Production orders can be sent from the back office and displayed on the operator screen to assist productivity

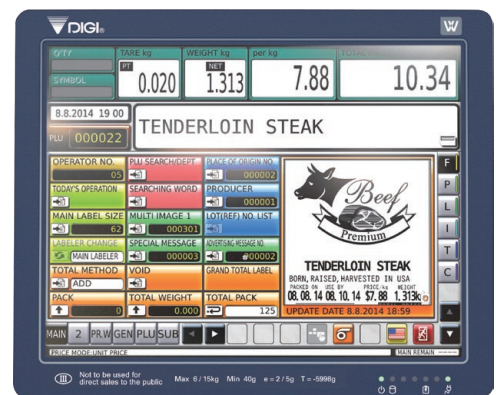

Options for Enhance Automation

Enhanced options open a world of possibilities to create a high-speed high-volume packaging line customised to your specific needs.

Factory-fitted options include; adding a POP and / or bottom labeller, linerless or die-cut labels, a choice of outfeed directions, "total labeller" for printing carton labels and an external console for remote operator control.

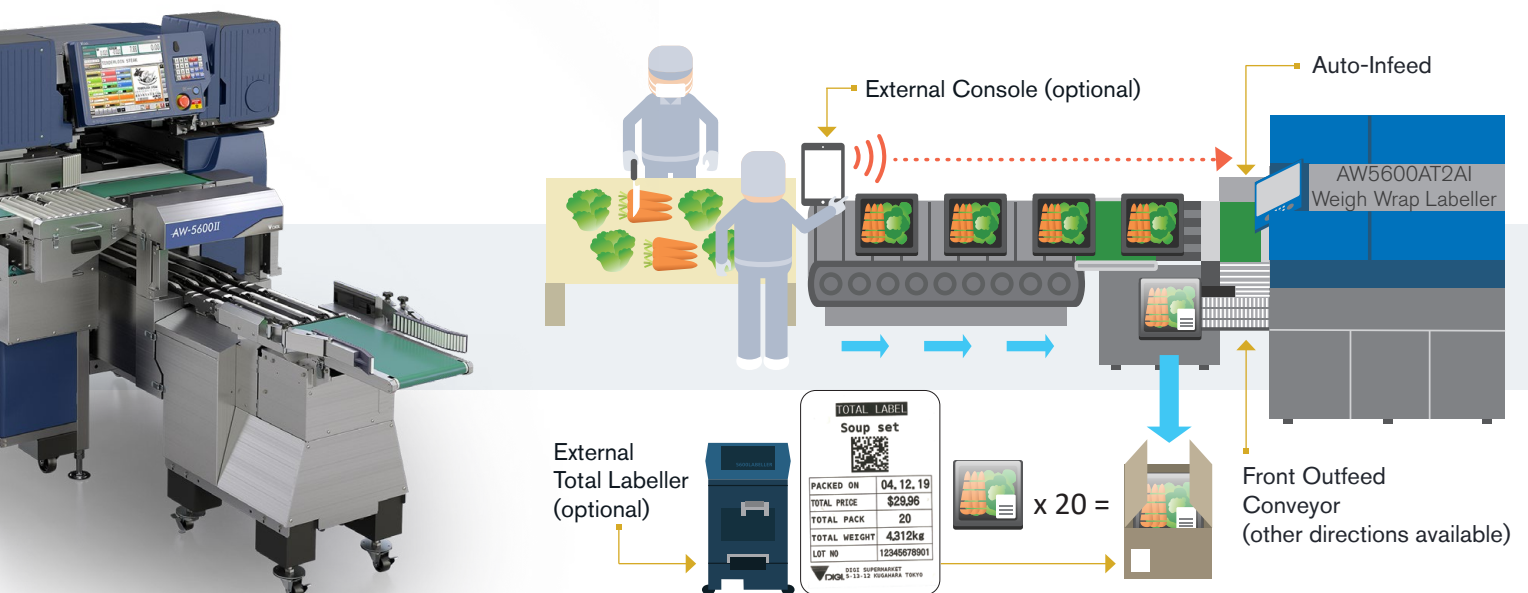

Fully Integrated Weigh-Wrap-Price Labeller

Model : AW5600AT2AI Series

Super-Stretch Film Technology

DIGI's unique super-stretch technology allows dynamic film savings.

The AW5600AT2I automatically determines the optimum wrapping conditions required to wrap the package. The film will be stretched to the required size to wrap the package enabling one roll of film to cover most of the trays in a store.

The result will be a smooth and cleanly wrapped product that doesn't leak, looks stunning on the store shelf for increase consumer appeal.

Smart Labelling

Multiple Labelling Options*

In addition to the main labeller, you have options for a second, POP and bottom labeller which can apply multiple labels in one process.

Use an optional POP labeller for a second eye-catching promotional style label. The AW5600AT2AIPOP will print and apply the POP label simultaneously with the main price label completely rationalising your backroom operations by saving time, labour and cost of labels.

The optional bottom labeller may be used to print and apply an additional label to the bottom of the package.

* Labeller configurations should be specified at time of ordering as not all options can be retrofitted.

80 mm Wide 300 dpi Thermal Head

The 300dpi thermal head enables clear and crisp label printing for enhanced consumer appeal. The 80 mm print width allows more information to be included on labels so that labelling regulations are met while still having room for attractive advertising messages.

Accurate Label Placement

The robotic arm labelling system automatically applies labels onto the wrapped trays. The position and angle of the label can be programmed specifically for each PLU if desired.



Linerless Labelling with Built-In Auto-Cutter

DIGI's linerless labelling technology with a unique built-in label cutter eliminates liner waste, increases flexibility and profit.

- **Eliminate wasted white space on big labels.** The auto-label-sizing feature eliminates unused space on the label and automatically adjusts the label size. This reduces the label cost and makes labels more attractive.
- **Increased flexibility in label formatting.** The auto-cut feature cuts from a continuous strip of linerless labels every time a label is printed. Variable label layouts and sizes can be printed from a single cut. This reduces the number of label types you need to store and time spent on changing label rolls for different product.
- **No more label liner waste.** The elimination of backing paper for labels (label liner) means no liner waste to store or dispose of which frees up valuable floor space and contributes positively to environmental goals.

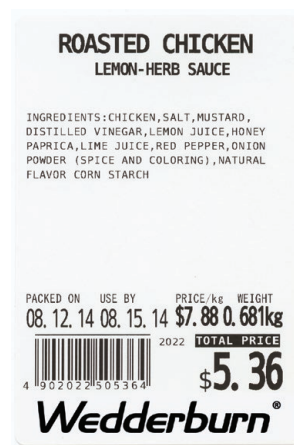

Specifications may change without notice

Fully Integrated Weigh-Wrap-Price Labeller

Model : AW5600AT2AI Series

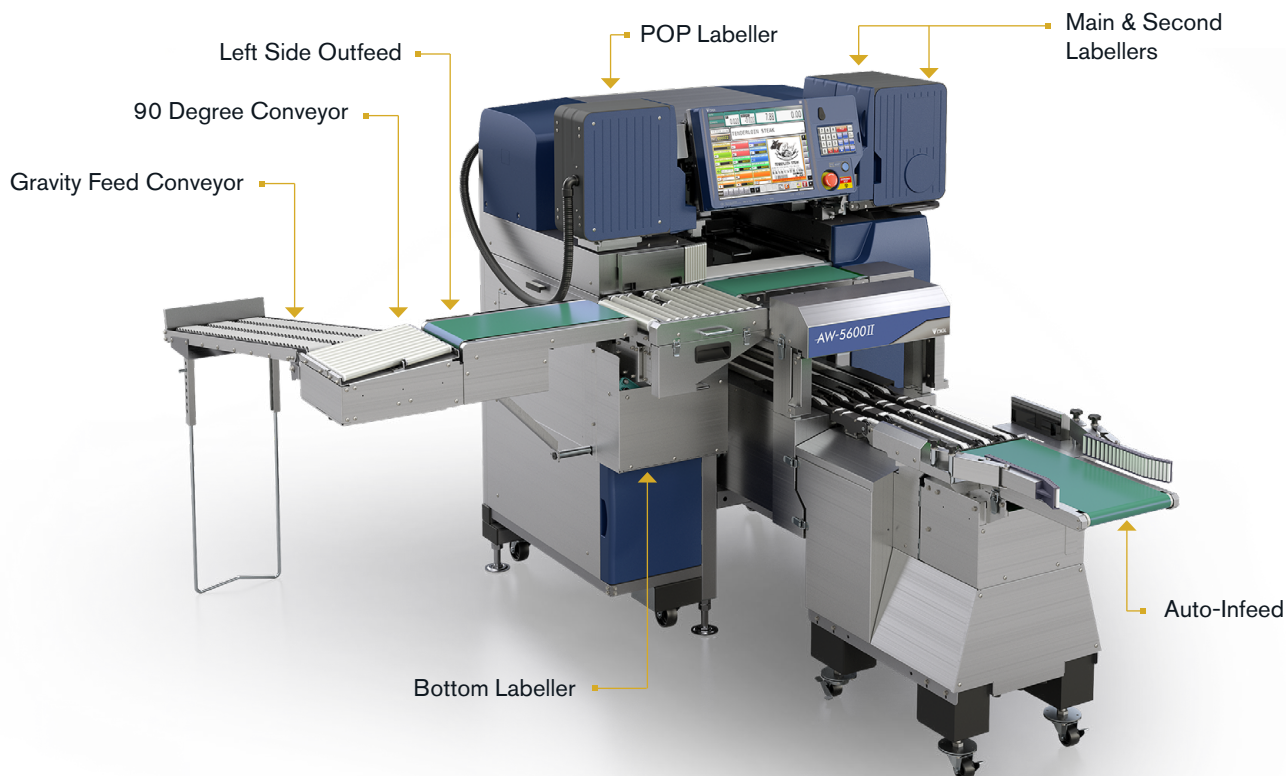

FEATURES OVERVIEW

- NMI approved for trade use
- small footprint that saves valuable floor space
- low noise design reduces operational noise
- easy to clean auto-infeed unit
- production orders can be sent from the back office and displayed on the operator display for efficient production
- easy to use with large 15" full colour touch screen and on-screen help messages
- capable of wrapping trays up to 150 mm high
- weighs, wraps, prices and labels an impressive speed of up to 36 packs per minute
- wide 300 dpi thermal head allows more detail to be printed on labels up to 80 mm wide
- accurate label placement that can be programmed for each PLU
- engineered to use new environmentally conscious linerless labels
- free-layout function keys allow users to customise the key layout
- fast PLU file communication via Ethernet
- RF capable for a cable-free environment

OPTIONS

- several labeller options: main, second, POP and bottom. Multiple labellers save time and label costs as two or three labels are applied in the same pass as trays are wrapped
- total labeller used to print total labels for shipping cartons
- external console to operate the wrapper remotely
- various outfeed directions available; front (standard), back (optional), side (optional)

Note: Labeller and Outfeed Conveyor configurations should be specified at time of ordering as not all options can be retrofitted

Specifications may change without notice

Fully Integrated Weigh-Wrap-Price Labeller

Model : AW5600AT2AI Series

SPECIFICATIONS

Capacity:	6 / 15 kg x 2 / 5 g (multi-interval)	
Package size (mm):	Width:	130 - 380
	Depth:	80 - 254
	Height:	10 - 150
	The maximum combination of the above dimensions is not available and the available package size depends on the film width.	
Wrapping speed:	Maximum 36 packs per minute	
Number of Film Rolls:	One	
Film Width (mm)	300 - 450	
Film Length (mm)	Maximum 1,500 metres	
Label Type:	Thermal Paper / Die Cut	
Label Width (mm):	40 - 80	
Label Length (mm):	28 - 150	
Label Roll Diameter (mm):	Maximum 210	
Label Core Diameter (mm):	76	
Display Panel:	15 inch TFT colour touch panel	
Keypad:	Pictorial or English	
Programmable Items:	PLU no., commodity name, ingredient, unit price, price, tare weight, sell-by-date, taste-by-date, department name, barcode (UPC, EAN), target weight, special message, advertising message, shop name & logo, extra print format, wrapping conditions, etc.	
Power requirement:	Single phase, 220 - 240 V, 50 Hz, 1.8 kw	
Net weight:	Approximately 490 kg (single labeller with auto-infeed)	

TOP VIEW

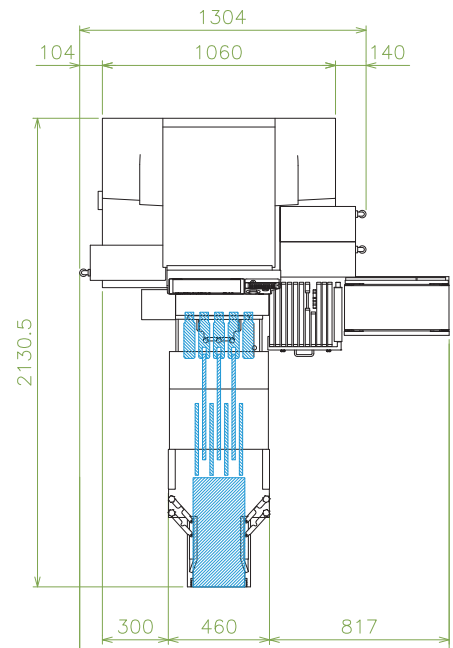

FRONT VIEW

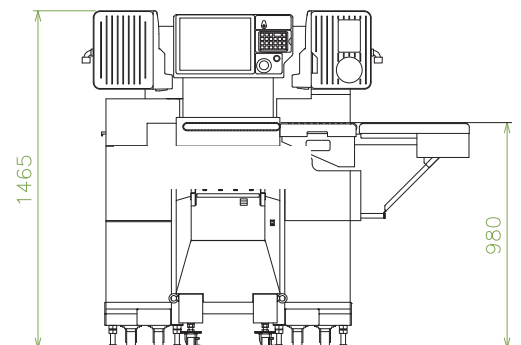

OUTFEED DIRECTIONS

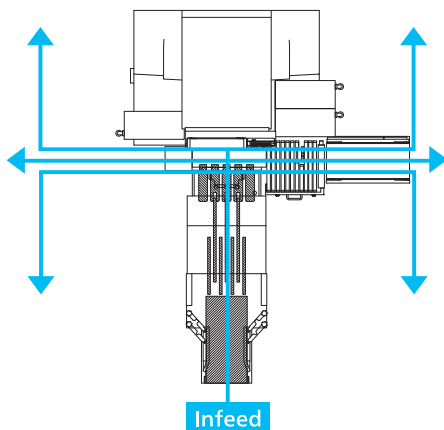

SIDE VIEW

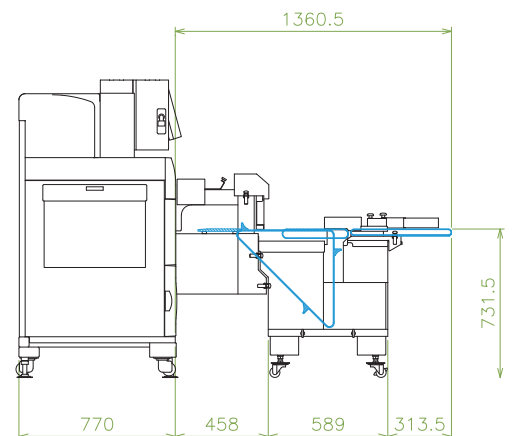

Specifications may change without notice

PACKAGING EQUIPMENT

LABELS | LABELLING EQUIPMENT | PACKAGING EQUIPMENT
ESL & DIGITAL SIGNAGE | WEIGHING SCALES | POS SYSTEMS
FOOD EQUIPMENT | MAINTENANCE & REPAIRS | HIRE

1300 970 111
enquiries@wedderburn.com.au
www.wedderburn.com.au