

Weigh Price Labelling Retail Scales

Model : TSSM120 Series

NMI approved price computing scales with label printer and a bright alpha-numeric display that can also display tare value of the product. These affordable retail labelling scales deliver impressive efficiency and are ideal for food retailers including butchers, delicatessens, poultry or seafood retailers.

FEATURES

- NMI approved for trade use
- simple to use
- bright alpha-numeric display (includes tare display)
- easy to change label with front loading cassette
- informative label printing including graphics and barcodes
- large memory to cater for most food labelling requirements
- fast processing & printing speed

OPTIONS

- pole or bench models available
- optional PLU maintenance software available



VARIATIONS

Model Number	Max Capacity	Graduation	Platform Size (mm)	Overall Dimensions (mm)
TSSM120B15K	15 kg	0 - 6 kg x 2 g 6 - 15 kg 5 g	355 (W) x 280 (D)	361 (W) x 427 (D) x 147 (H)
TSSM120B30K	30 kg	0 - 15 kg x 5 g 15 - 30 kg x 10 g	355 (W) x 280 (D)	361 (W) x 427 (D) x 147 (H)
TSSM120P15K	15 kg	0 - 6 kg x 2 g 6 - 15 kg 5 g	355 (W) x 280 (D)	361 (W) x 500 (D) x 584 (H)

See page 2 for additional specifications

Specifications may change without notice

WEIGHING SCALES

Weigh Price Labelling Retail Scales

Model : TSSM120

SPECIFICATIONS

Model	TSSM120B15K	TSSM120B30K	TSSM120P15K
Capacity	15 kg	30 kg	15 kg
Graduation	0 - 6 kg x 2 g 6 - 15 kg 5 g	0 - 15 kg x 5 g 15 - 30 kg x 10 g	0 - 6 kg x 2 g 6 - 15 kg 5 g
Platform Size (mm)	355 (W) x 280 (D)	355 (W) x 280 (D)	355 (W) x 280 (D)
Overall Dimensions (mm)	361 (W) x 427 (D) x 147 (H)	361 (W) x 427 (D) x 147 (H)	361 (W) x 500 (D) x 584 (H)
Number of Presetn Keys	32	32	56
Display Panel	LCD with white backlight		
Type	LCD with white backlight		
Tare Weight	4 digits		
Weight	5 digits		
Unit Price	6 digits		
Total Price	7 digits		
Second Line Display	25 characters		
Printer	Thermal printers		
Label Type	Thermal printers		
Max Printing Width	60 mm		
Max Printing Speed	110 mm per second		
Label	Thermal labels		
Label Type	Thermal labels		
Max Label Width	60 mm		
Label Length	25 mm - 220 mm		
Power Source	Single phase		
Operating Humidity	15% ~ 85% RH		
Operating Temperature	-10 °C ~ +40 °C		
Standard Interface	AC receptacle. 1 x RS232C. Ethernet		
Software	Optional PLU maintenance software available		
Net Weight	10.5 kg	10.5 kg	13.1 kg

Specifications may change without notice

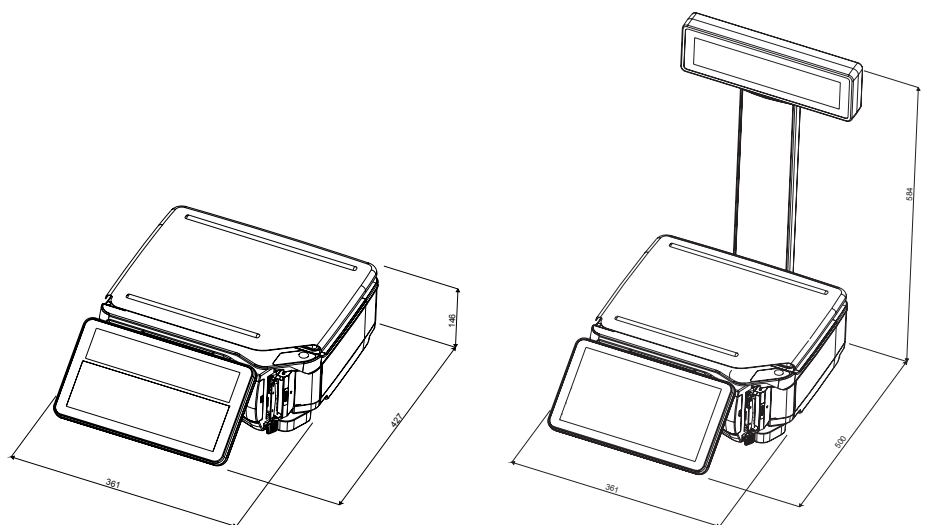

Bench model TSSM120B

Pole model TSSM120P

WEIGHING SCALES